



INSTALLATION GUIDE

SEEN IRIS 860 sensor

SEEN IRIS 860 Cab Box

SEEN IRIS-i camera

This guide contains instructions and information to support the installation of SEEN System products, including the IRIS 860 sensor and IRIS-i camera.

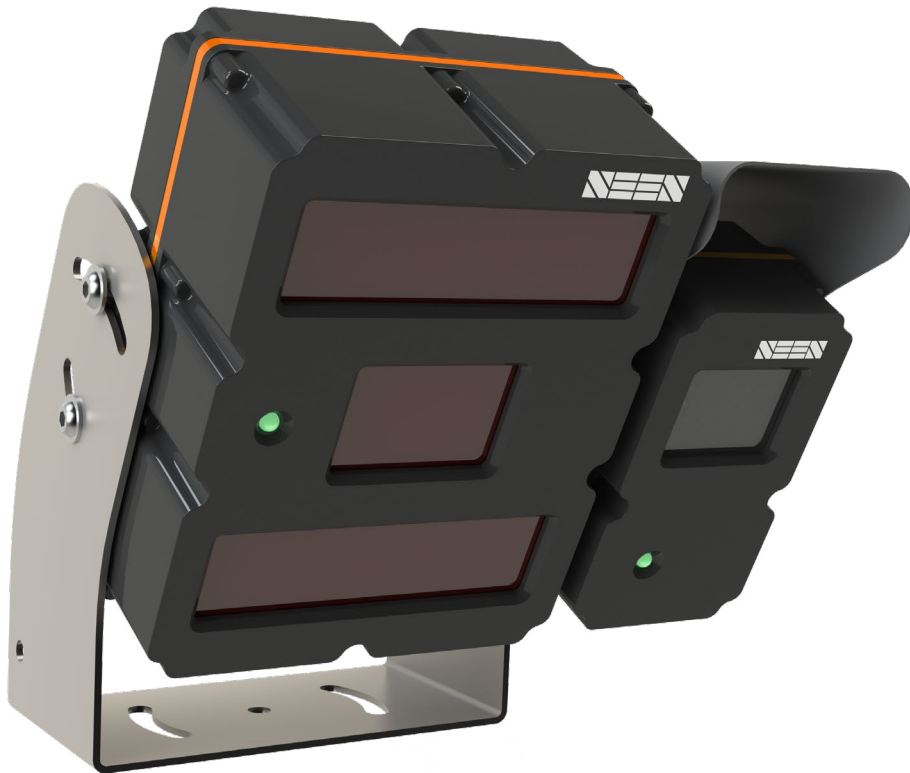

Contents

Installation Instructions	
IRIS 860 sensor	
Introduction	5
Mounting	7
Sensor wiring	9
Testing	10
Troubleshooting	11
IRIS 860 Cab Box	
Introduction	13
Wiring	14
Testing	15
Troubleshooting	15
IRIS 860 Weather Shield	17
IRIS-i camera	
Introduction	19
Serial Number Record	20
Installation	21
Antenna	23
LED indications	23
IRIS 860 accessories	
IRIS 860 Setup Dongle	24
Buzzer Cap	25
Machine templates	
Introduction	26
Sit-down Counterbalance Forklift	27
Stand-up Counterbalance Forklift	28
Reach Truck	29
Sensor settings	
Sensor settings	30
How to change the settings	31
Technical reference resources	
Using a DC/DC converter	33
Connect a third party accessory	35
Sensor internal self check function	37
Changing settings via Cab Box Sensor Cable	38
Cab Box cable shortening and threading	39
IRIS-i camera Internal memory	40
Product Specifications	
IRIS 860 sensor	42
IRIS 860 Cab Box	44
IRIS-i camera	46
General	
Warranties	48
Maintenance	49
Support	49

IMPORTANT

SEEN IRIS 860 sensors can provide collision warning assistance to the operator but do not replace the need for proper operator training and best practice safe operating procedure. While IRIS 860 sensors can alert the machine operator to a potential collision, the operator is always fully responsible for the safe operation of the equipment. IRIS 860 sensors do not comply with the regulatory standards required for devices which are intended to directly control vehicle or machine safety functions. Using the sensor accessory port to control a vehicle or machine function is entirely at your own risk. Detection can never be guaranteed.

IRIS 860 sensors are a CLASS I LASER PRODUCT. Disassembly or modification of this device may result in hazardous radiation exposure.

IRIS 860 sensors and accessories have no user serviceable parts. Opening the enclosure will void the warranty.



SEEN IRIS 860 sensor

INSTALLATION GUIDE

For additional resources about the SEEN Safety system, please refer to www.seensafety.com/resources.

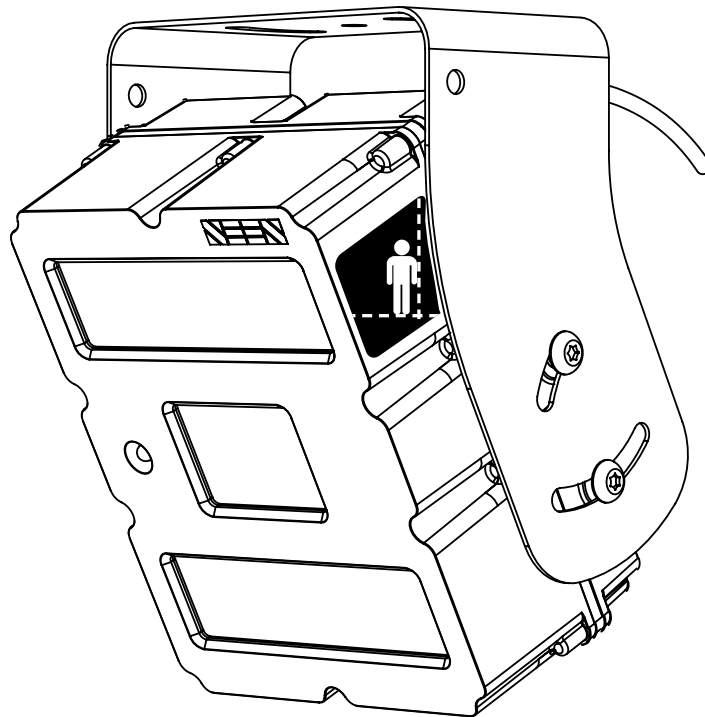

IRIS 860 sensor

SEEN IRIS 860 sensors are designed for use on heavy mobile equipment like forklifts and wheel loaders. The sensor uses non-visible infrared laser light to detect the presence of retro-reflective material, such as the reflective tape found on day/night high visibility PPE and markers. Detection is indicated by an audible alert.

The detection zone and alert volume can be changed to suit the operating environment.

Before you start installation

1. Read the installation instructions in full before starting.
2. Ask the customer for their **Machine template**, which specifies where the sensor should be installed on the machine, and how it should be set up.

If the customer doesn't have a template, please refer to SEEN's generic [Machine Templates](#) on page 26, which outline recommended mounting specifications for a variety of common machine types.

3. Before going on-site, ensure you have an exact plan of how you will mount the sensor(s) and any custom mounting attachments, if required.

Related section

[Sensor mounting location](#) - Pg. 7

[Machine Templates](#) - Pg. 26

Check the vehicle's power supply voltage against the IRIS 860 sensor maximum voltage rating sticker and use a DC/DC converter if necessary.

Related section

[Using a DC/DC voltage converter](#) - Pg. 33

4. Check with the customer whether any additional accessories need to be installed. These may include a Weather Shield, Cab Box, and IRIS-i camera. You will need an IRIS 860 Setup Dongle (P/n SI-138) to apply the sensor settings specified in the Machine Template.



Sensor box contents

- 1 x IRIS 860 sensor
- 1 x stainless steel mounting bracket
- 1 x power cable 4m (13ft)
- 4 x stainless screws (M6)



Sensor box contents



IRIS 860 sensor mounted in bracket with power cable attached.

IRIS 860 sensor parts

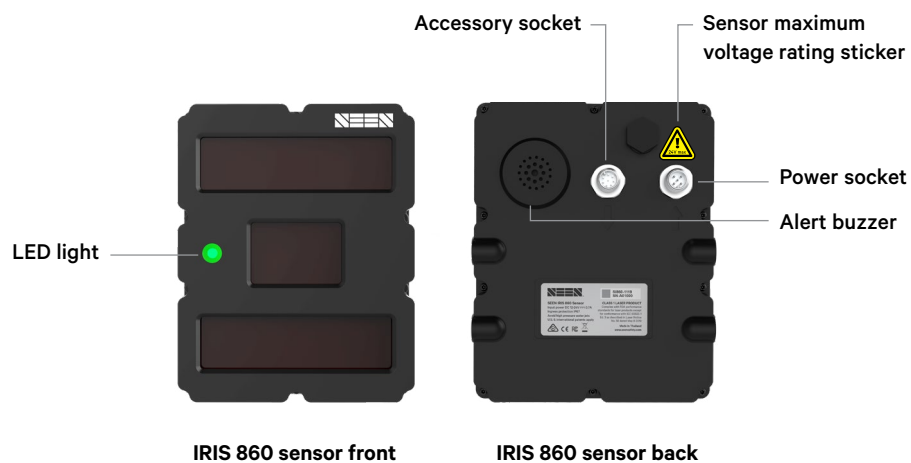

1. Sensor mounting location

The sensor's mounting location, angle, and settings should be specified by the customer in a **Machine Template**.

If one is not available, please refer to SEEN's generic [Machine Templates](#) on page 26. These detail the recommended IRIS 860 mounting specifications for a variety of common machine types.

Related section
[Machine Templates](#) - Pg. 26

Make sure that the sensor is protected against impact. If the forklift works inside containers, ensure the sensor does not protrude above the highest point of the frame.

A custom mounting attachment may be needed to attach the IRIS 860 mounting bracket in the desired position.

2. Sensor bracket orientation

The supplied mounting bracket can be used on horizontal, vertical, or angled surfaces. Select the bracket orientation that best suits the installation requirements.



Over



Under



Vertical



Sensor mounting bracket

3. Attach the mounting bracket to the machine

Securely bolt the mounting bracket to a solid surface using at least two appropriate M6 fasteners.

WARNING. Do not drill into any roll-over or falling-object protection structure (ROPS / FOPS) as this may compromise the strength of the structure and void the machine warranty.

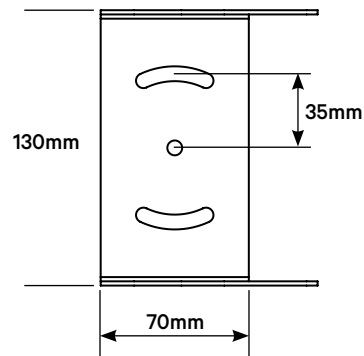

4. Mount the sensor in the bracket

If a Weather Shield is used, it needs to be installed at this stage.

Related section

[Weather Shield installation](#) - Pg. 17

[Machine Templates](#) - Pg. 26

- Align the sensor's four mounting holes with the slots in the mounting bracket.
- Insert each M6 screw (supplied) and finger-tighten.
- Adjust the sensor to the correct angle. **The figure on the alignment sticker should be upright.***
- Tighten the four M6 mounting screws to 10Nm.

CHECK. Check that the sensor is the right way up and that the figure on the alignment sticker is upright*.

*If the sensor is mounted higher than approximately 2m (6.5ft) it may need to be angled slightly further towards the ground.



The alignment sticker is found on the side of the sensor.

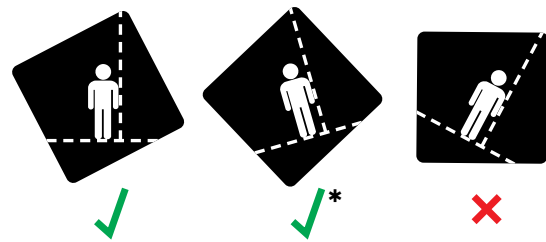

If a Cab Box is being installed (required for closed-cab machines), skip to [Cab Box installation](#) on page 13.

Related sections

[Cab Box installation](#) - Pg. 13

[Using a DC/DC voltage converter](#) - Pg. 33

[Troubleshooting](#) - Pg. 11

1. Check the sensor voltage

Check the sensor's maximum voltage rating sticker. It will either be 24V or 80V.

If the vehicle's power supply exceeds the maximum voltage indicated on the sticker, a DC/DC voltage converter must be used.

2. Wire in the Sensor Power Cable

IMPORTANT. Ensure the vehicle is turned off before starting work.

The 4-PIN, 4m (13ft) Sensor Power Cable must be connected to the vehicle's electrical power supply. The following three wires must be connected:

BROWN (Power)

The Brown wire must continuously receive DC power when the vehicle is on. A DC/DC voltage converter may be needed.

BLACK (Direction signal) DC 3.5-100V \approx 1mA

The Black wire must be connected to the vehicle's direction signal (in most cases the reverse signal). The reverse signal must be continuous (not pulsed) while the vehicle is in reverse gear. Ensure the voltage on the Black wire is less than +1V when the direction signal is not high.

3. BLUE (Ground)

The Blue wire must be connected to the vehicle's ground.

Once the Sensor Power Cable is wired to the vehicle, carefully connect the M12 plug connector to the sensor's 5-PIN M12 power socket. **Finger-tighten only.**



The sensor's maximum voltage rating sticker will be either 24V or 80V.



M12 connectors.
Finger tighten only.
Do not use tools.



Related sections

[Troubleshooting](#) - Pg. 11

[Sensor settings](#) - Pg. 30

Once installed the sensor must be tested to ensure it works correctly.

SAFETY FIRST. For your safety ensure the vehicle engine is off and the park-brake is on at all times.

Check the mounting angle

Check that the face of the sensor is angled down correctly, and that the figure on the alignment sticker is upright.

Test the power supply

Switch the vehicle on. The sensor should have a steady green LED while the machine is switched on.

Test the reverse signal connection*

Note. If the factory default settings have been changed, the functionality may differ from that described below.

Test Method:

1. Place a retro-reflective safety vest (or similar) in the sensor's detection zone (approximately 2-3 meters from the sensor). **The sensor should not alert.**
2. Now, put the vehicle in reverse and repeat the test. This time **the sensor should alert.**

When the sensor alerts, the LED will turn red and the sensor will emit a loud audible tone.

*By default IRIS 860 sensors are factory pre-set so they can only alert while receiving a direction signal (usually the reverse signal) from the vehicle. This setting can be changed using the Sensor Setup App and the IRIS 860 Setup Dongle.

Related section

[How to change the sensor settings](#) - Pg. 31



The sensor LED should be green while the vehicle is powered on.

1. The sensor LED is green, but the sensor will not alert.

Possible cause: No reverse signal present. By default sensors are set so they can only alert while receiving a direction signal (usually reverse) from the machine. Check the black wire is connected to the vehicle's reverse signal.

Possible cause: The retro-reflective material is too close to the sensor. Move further back. Detection starts 0.8m /2.6ft from the sensor face.

Possible cause: The retro-reflective material is worn out or is of insufficient size to enable detection.

Related Resources

seensafety.com/resources/reflective-tape-requirements

2. A sensor that is set so that it can only alert during reverse, will alert when the vehicle is not in reverse.

Possible cause: The reverse signal input wire (black) is twisted together with the power wire, meaning the reverse signal is always high. Connect the black wire to the reverse signal.

Possible cause: Voltage issue on the reverse signal. The reverse signal input (black) must have no more than +1V when it *not* high, and more than 3.5V when it is high.

3. The sensor is correctly wired but the sensor/s do not behave in the expected way.

Possible cause: An electrical earthing issue on the reverse signal. Check that the ground reference on the reverse signal is the same as the ground reference on the sensor power supply. Also refer to [point 7](#).

4. The sensor repeatedly beeps and flashes with the sequence long-short-short, long-short-short.

Cause: Blocked window. Clean the windows and the self-check alert should cease. If the sensor is operating in a cold-store freezer, ice on the window maybe triggering the self checking function. Contact SEEN Support.

6. The sensor is beeping and flashing and the sequence is NOT long-short-short, long-short-short.

Cause: Internal fault detected. There are no user serviceable parts. Contact your supplier.

7. Direction signal grounding issue.

Applies to a sensor connected to a direction signal input (usually reverse). If a DC/DC converter is used refer to [page 33](#).

Note: In this example the direction signal is REVERSE.

Problem: The sensor is correctly powered and connected to the reverse signal, but the sensor does not alert even when the reverse signal is active. The reverse signal and sensor power supply may not share a common ground.

To check the reverse signal ground:

- Unplug the sensor power cable
- Switch the vehicle ignition ON (preferably without starting the vehicle for safety)
- Attach a voltmeter across the ignition power pin (+) and the ground pin (-) of the power cable. The voltage should be between +10V and +29V. Refer to the plug diagrams opposite.
- Next, attach the voltmeter across the reverse direction pin and the ground pin (-). When the vehicle is NOT in reverse, the voltage should measure between 0V and +1V. When the vehicle IS in reverse it should measure between +3V and +100V.

If the vehicle is in reverse and the voltage is not 3-100V between the ground pin (-) and the reverse direction pin, there may be a grounding issue.

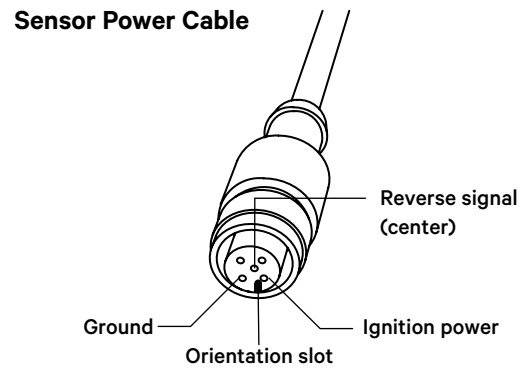

INSTALLATION GUIDE

Introduction

Before you start

Check the vehicle's power supply voltage against the Cab Box's maximum voltage rating and use a DC/DC converter if necessary.

Purpose

On an enclosed cabin vehicle, the Cab Box provides an audible alert to the operator inside the cab. Up to four sensors can be connected to each Cab Box.

Components

- Cab Box**
 Installed in the driver's cab
- Cab Box Power Cable**
 Connects to the vehicle's power supply and direction signal. (4pin cable included with each Cab Box)
- Cab Box Sensor Cable**
 Used to connect the sensor back to the Cab Box.
 Available in lengths of 5m (16ft), 10m (33ft), 15m (50ft) or 20m (65ft).

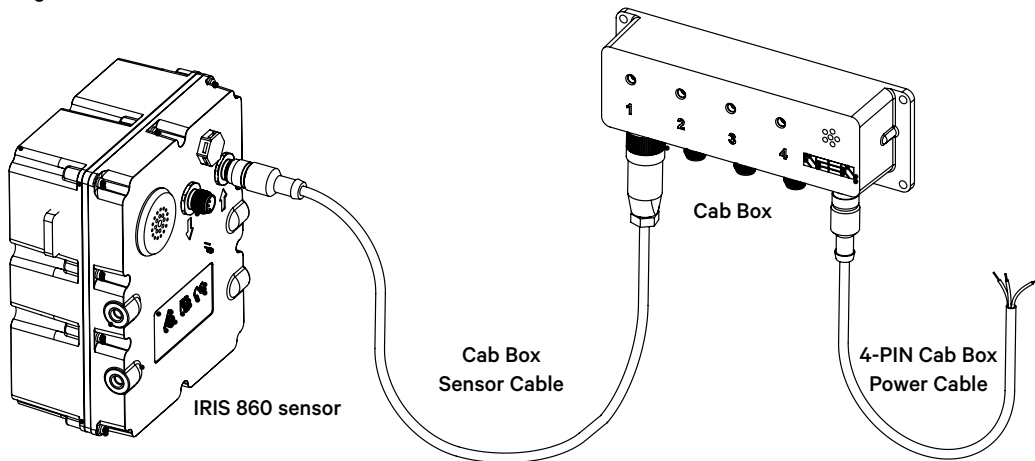

Cab Box installation example:

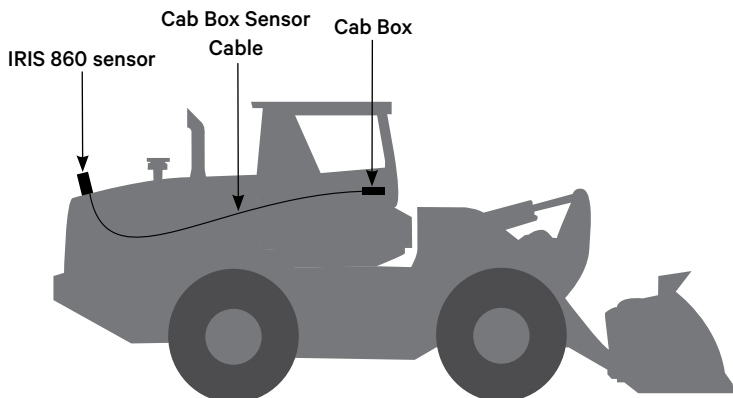

1. Check the voltage

If the vehicle's power supply exceeds 24V a DC/DC voltage converter must be used.

Related section

[Using a DC/DC Converter](#) - Pg. 33

The Cab Box may draw up to 4.0A.

2. Connect Cab Box Power Cable

IMPORTANT. Only use the 4-PIN Cab Box Power Cable provided with the Cab Box. Do not use the sensor 5-PIN power cable which is not needed for Cab Box installations.

Wire the 4-PIN, 4m (13ft) Cab Box Power Cable to the vehicle:

- BROWN (Power) DC 12-24V \approx 4A**
 The Brown wire must continuously receive DC power when the vehicle is switched on. A DC/DC voltage converter may be needed.
- BLACK (Direction signal) DC 3.5-100V \approx 1mA**
 The Black wire must be connected to the vehicle's direction signal (in most cases the reverse signal). The reverse signal must be continuous (not pulsed) while the vehicle is in reverse gear. Ensure the voltage on the Black wire is less than +1V when the direction signal is not high.
- BLUE (Ground)**
 The Blue wire must be connected to the vehicle's ground.

3. Connect Cab Box Sensor Cable

Connect each sensor to the Cab Box using the Cab Box Sensor Cable. One end of the cable has a re-wireable plug that can be removed to assist the threading of the cable through the machine chassis or to shorten the cable.

Related section

[Cab Box Sensor Cable shortening and threading](#) - Pg. 39

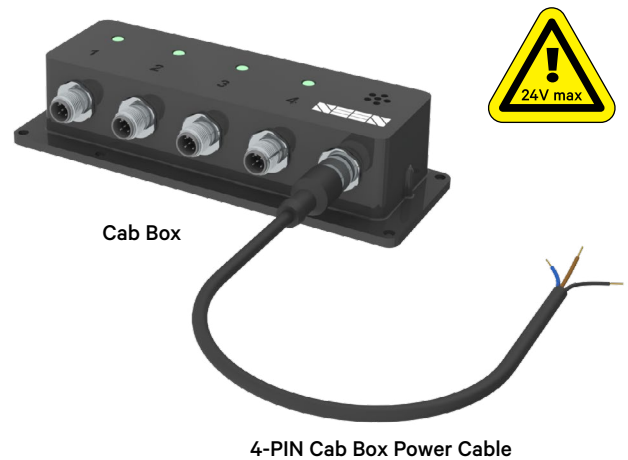

M12 connectors.
Finger tighten only.
Do not use tools.

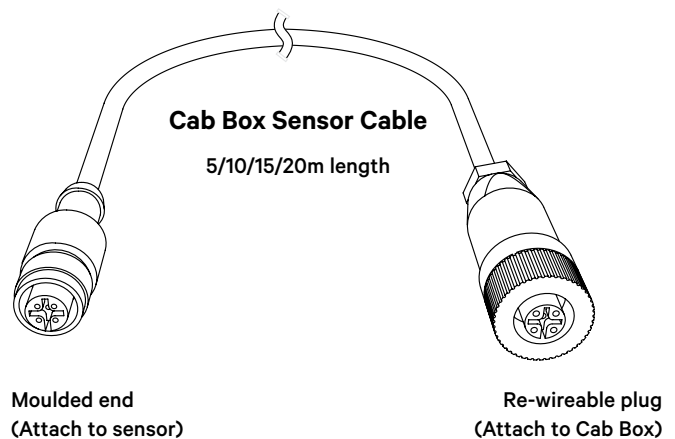

The Cab Box alert mirrors the LED and audible alert state of its connected sensor/s.

- When the vehicle is first switched on the sensor will Boot, indicated by a single beep and red LED flash followed by a steady green LED on the sensor and Cab Box.
- While the vehicle is on the sensor and Cab Box should have a steady green LED.
- When the sensor is detecting the sensor and Cab Box will have an audible alert and red LED*.

*By default IRIS 860 sensors are factory pre-set to only detect if they are receiving a direction (usually reverse) signal from the vehicle. This setting can be changed in the Sensor Setup App.

Related section

[How to change the sensor settings](#) - Pg. 31



2 x Cab Box Sensor Cables are shown attached. The green LED indicates that a sensor is attached.

Cab Box Power Cable

Troubleshooting

1. The Cab Box is correctly wired but the connected sensor/s do not behave in the expected way.

Possible cause: Wrong power cable. Ensure you use the 4 PIN Cab Box power cable supplied with the Cab Box. Do not use the 5 PIN sensor power cable supplied with each sensor.

2. Direction signal grounding issue.

Applies to a Cab Box connected to a direction signal input (usually reverse). If a DC/DC converter is used refer to [page 33](#).

Note: In this example the direction signal is REVERSE.

Problem: The Cab Box is correctly powered and connected to the reverse signal, but the sensor does not alert even when the reverse signal is active. The reverse signal and sensor power supply may not share a common ground.

To check the reverse signal ground:

- Unplug the sensor or Cab Box power cable
- Switch the vehicle ignition ON (preferably without starting the vehicle for safety)
- Attach a voltmeter across the ignition power pin (+) and the ground pin (-) of the power cable. The voltage should be between +10V and +29V. Refer to the plug diagram opposite.

Cab Box Power Cable

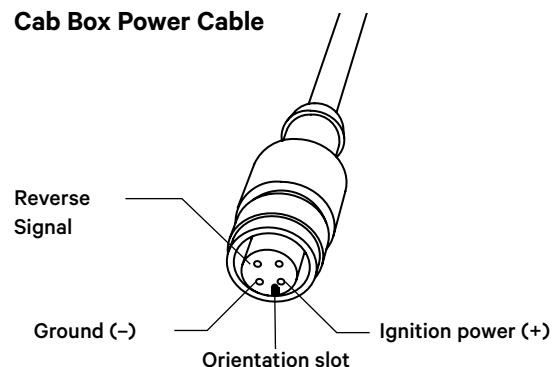

- Next, attach the voltmeter across the reverse direction pin and the ground pin (-). When the vehicle is NOT in reverse, the voltage should measure between 0V and +1V. When the vehicle IS in reverse it should measure between +3V and +100V.

If the vehicle is in reverse and the voltage is not 3-100V between the ground pin (-) and the reverse direction pin, there may be a grounding issue.

Related section

[Troubleshooting \(IRIS 860 sensor\)](#) - Pg. 11

IRIS 860 Weather Shield

INSTALLATION INSTRUCTIONS

Related section

[Mount the sensor in the bracket](#) - Pg. 7

A Weather Shield is recommended to protect the IRIS 860 sensor from rain, heat and UV when used outdoors.

If a Weather Shield is used, follow the installation steps below.



Sensor + Weather Shield

Step 1

Insert and finger tighten the two lower screws only. Set the sensor to the correct angle.

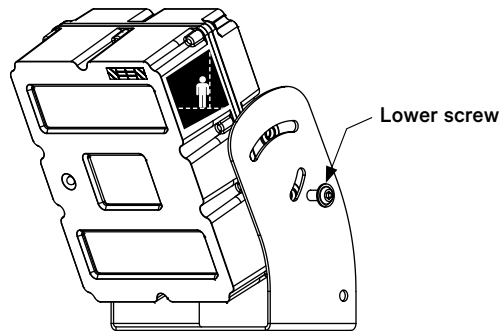

Step 2

Fit the Weather Shield over the sensor and bracket, so the round holes on each side fit around each screw head.

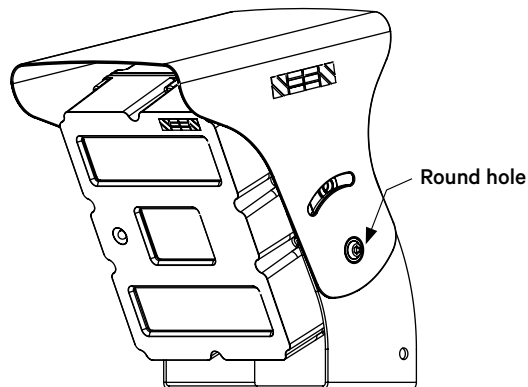

Step 3

Insert the remaining two screws and finger tighten. Check the alignment of the sensor and weather shield. Evenly tighten all four screws to 10Nm (maximum).

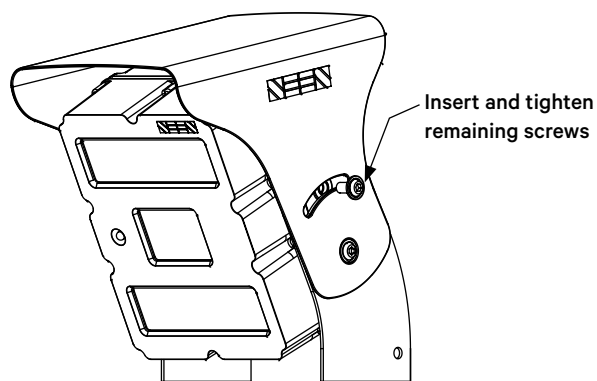



SEEN IRIS-i camera

INSTALLATION GUIDE

This guide is intended for anyone installing an IRIS-i camera on a IRIS 860 sensor.

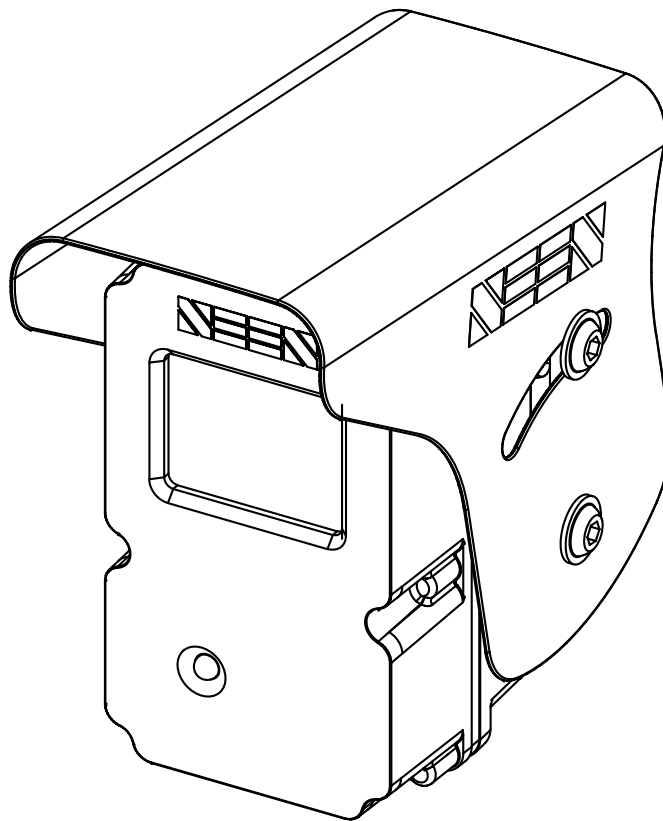

IMPORTANT

Install and test the IRIS 860 sensor before installing the IRIS-i camera.

This installation and set-up guide has been prepared with all due care and attention, however, Seen Safety Limited cannot be held responsible for any errors or omissions in this guide or any consequences thereof.

- **Fully install and test the IRIS 860 sensor before attaching the IRIS-i camera.**
- Read these instructions in full before starting.
- IRIS-i cameras do not record sound.

Note. Detection events are recorded and saved in the camera memory even if the IRIS-i is not connected to the network. These detections will be uploaded once the device connects to the network. [See page 40.](#)

Overview

The IRIS-i camera is designed to be attached to an IRIS 860 sensor. Detection information is automatically uploaded by IRIS-i to SEEN Insight (insight.seensafety.com).

When powered, activated IRIS-i cameras automatically connect to the mobile data network via an embedded roaming SIM card.

IRIS-i cameras upload the following information about each detection event:

- A still image
- The time, date, duration, and closest distance
- Trace path through the detection zone
- Video (optional upload).

Requirements

- 3G / 4G mobile coverage
- An installed IRIS 860 sensor

In the Box

- IRIS-i camera
- 300mm M12 connector cable
- Weather shield
- Mounting bracket
- Antenna + 600mm cable
- Antenna mounting bracket
- 4 x M6 x 12mm hex head screw
- 2 x M6 x 16mm hex head screw
- 2 x M6 Nylock nut



IRIS 860 sensor and IRIS-i camera



IRIS 860 sensor and IRIS-i camera (back)

Fully install and test the IRIS 860 sensor *before* attaching the IRIS-i camera.

The IRIS-i camera can be attached to either side of an IRIS 860 sensor. Configure Step-1 according to which side of the sensor the camera will be mounted on.

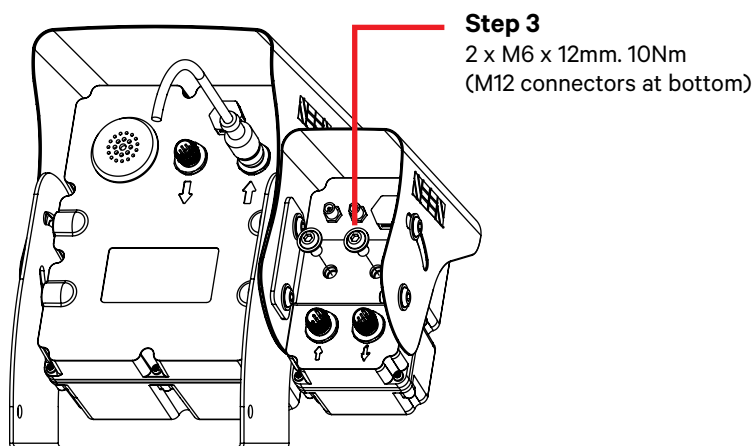
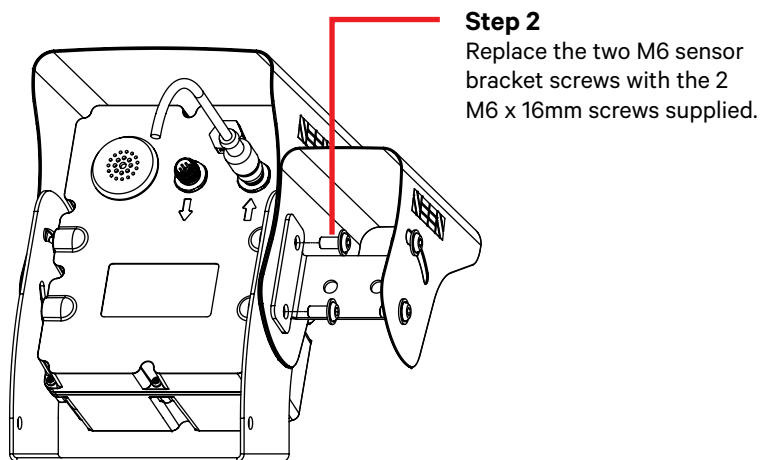
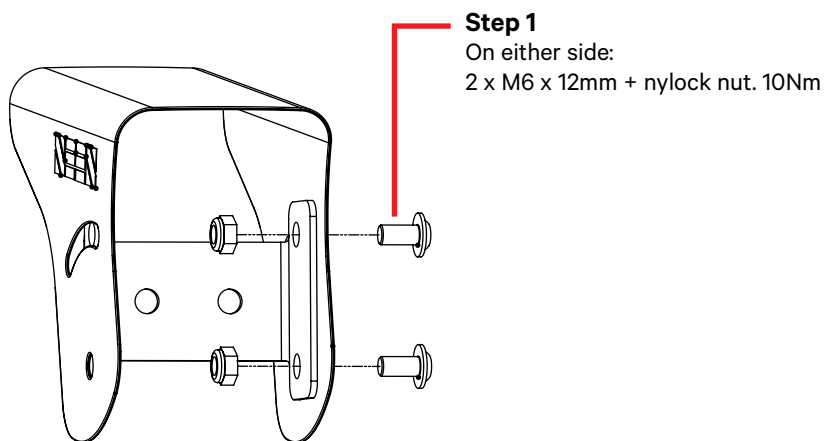

Step 4

Remove the sensor power cable from the back of the sensor, and plug it into the bottom left connector at the back of the camera.

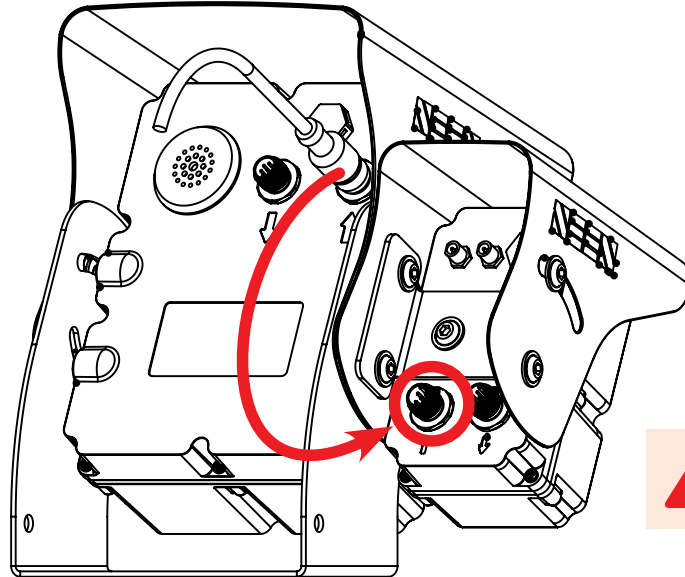

Finger tighten only.
Do not use tools.

Step 5

Connect sensor and camera using the 300mm M12 connector cable

Note: the sensor accessory socket is not used.

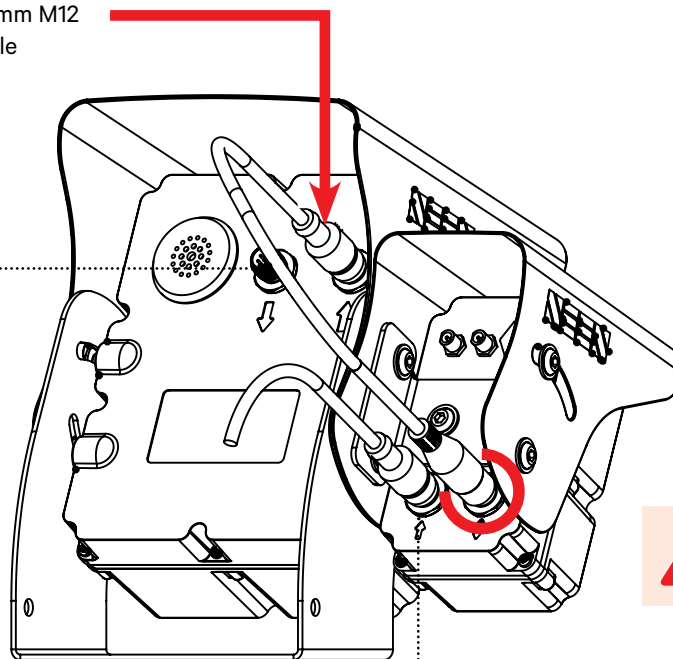

Finger tighten only.
Do not use tools.

Power cable

Antenna Connection

1. The antenna should be mounted upright with minimal shading from metallic surfaces. (Before attaching the antenna check that the antenna cable can reach back to the camera.)
2. Connect the antenna cable to the **centre** antenna socket.
Finger tighten only, do not use tools.

LED Indication

BLUE LED

A solid blue LED indicates that the IRIS-i is powered and can communicate with the IRIS 860 sensor.

FLASHING LED

A flashing LED indicates that the IRIS-i camera is not correctly attached to the IRIS 860 sensor.

Troubleshooting

Flashing LED

- Check that the 300mm M12 connector cable is not plugged into the sensor's accessory port by mistake. [Refer to page 22](#) for correct connection instructions.
- Check that the cable is plugged into both the camera's 8 pin M12 sensor socket (bottom right of camera) and the sensor's 5 pin M12 power socket (top right of sensor).

IRIS-i Camera

IMPORTANT

The antenna must be mounted at least 100mm away from the IRIS 860 sensor. DO NOT attach the antenna to either the sensor bracket or the camera bracket because it may interfere with the sensor operation.

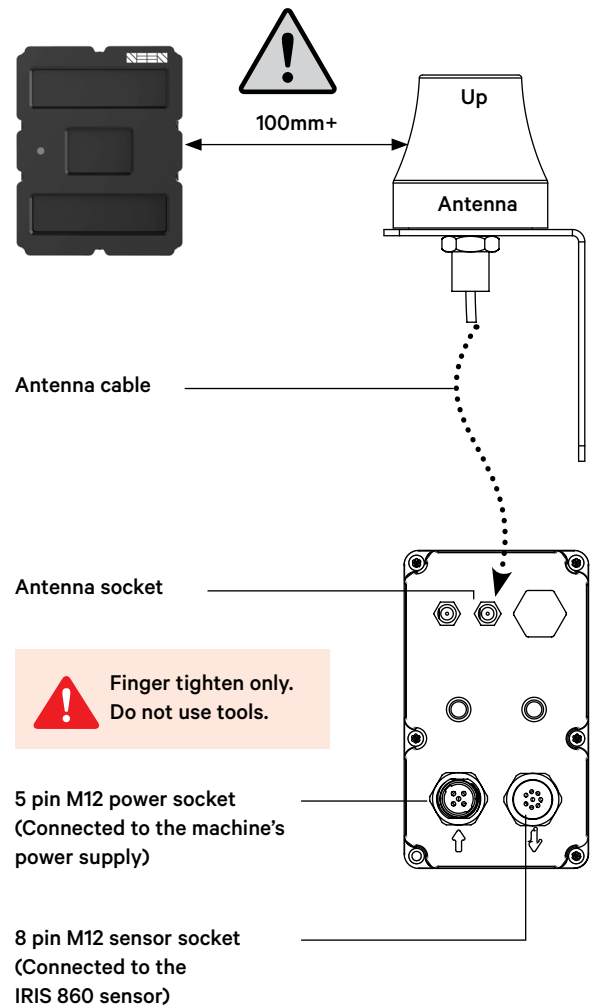

IRIS 860 accessories

CONTENTS

IRIS 860 Setup Dongle	24
Buzzer Cap	25

IRIS 860 Setup Dongle

The IRIS 860 Setup Dongle allows you to power and configure the IRIS 860 sensor, using a USB-C power pack (not included).

Connecting the dongle

Download the free SEEN IRIS 860 setup app from the App Store, or Google Play Store onto a phone or tablet.

Plug the dongle cable into the 5 Pin connector on the back of the sensor, and a USB-C Power Bank (not included) into the USB-C input port on the dongle.

When the dongle LED turns blue, the dongle and sensor are powered up and the sensor will be working.

Make sure that Bluetooth is turned on, then use the IRIS 860 setup app to connect to the dongle. When the dongle's LED has turned green, the sensor's configuration settings are ready to be changed in the app.

Optional:

Secure the power bank to the dongle using the double sided adhesive tape on the reverse of the dongle.

Related section

[How to change the sensor settings](#) - Pg. 31

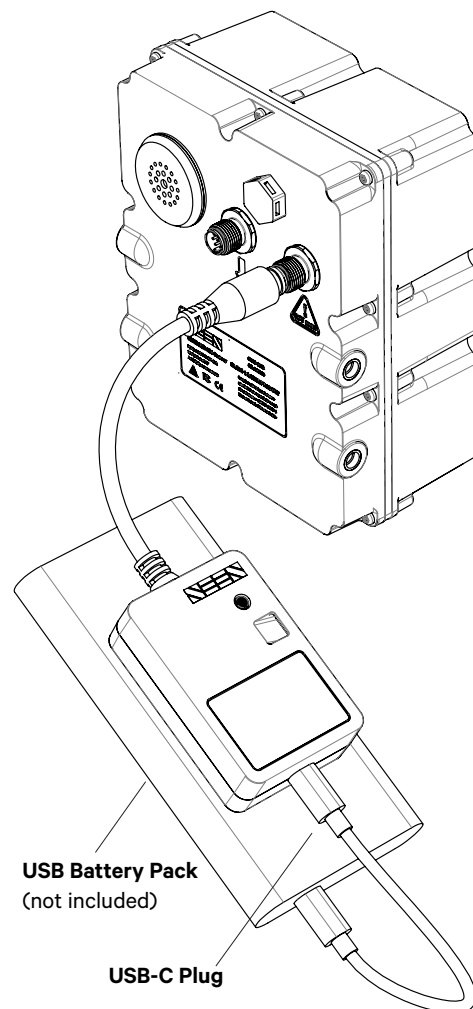

Buzzer Cap

The Buzzer Cap can be clipped over the sensor buzzer to reduce the alert volume from the default 94dB down to 80 dB. The buzzer is located on the back of the sensor.

The sensor's alert volume can also be changed within the sensor settings.

Related section

[How to change the sensor settings](#) - Pg. 31

Attaching the Buzzer Cap

1. Align center hook on the buzzer cover with central hole in the buzzer

2. Ensure the slot is at the bottom

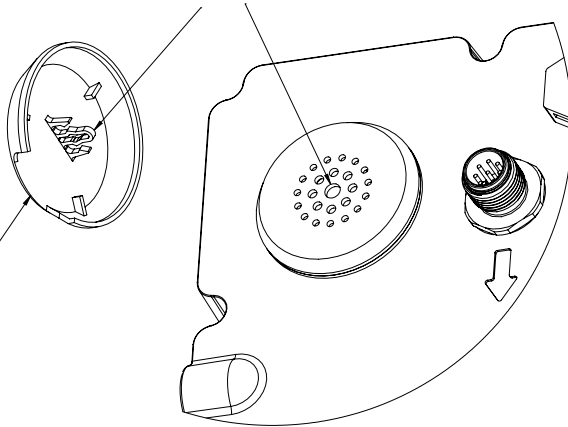

3. Gently press the cover until the hooks snap into place

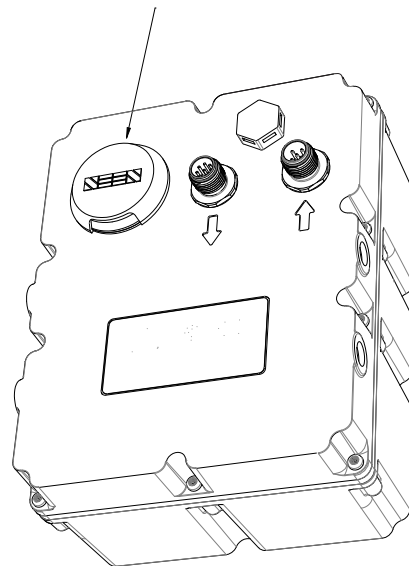

Back of the IRIS 860 sensor



MACHINE TEMPLATES

CONTENTS

Sit-down counterbalance forklift	27
Stand-up counterbalance forklift	28
Reach Truck	29

Introduction

SEEN IRIS 860 sensors can be fitted all brands and models of mobile heavy machinery.

The sensor's mounting location, angle, settings and required installation equipment may vary, depending on the machine type and the specific operating environment.

It is the customer's responsibility to decide the best setup for their machines and workplace. They may provide the installer with a reference template which details the required setup and settings. If this is not available, please refer to the Machine Templates in this section.

The Machine Templates cover the most common machine types, and the recommended sensor setups for each. For additional templates, please refer to SEEN's resources at seensafety.com/resources.

SEEN equipment to install

1 x IRIS 860 sensor SI-120

Installer notes

- The sensor can be located either below or above the overhead guard unless the truck has a container mast, in which case the sensor must be mounted below the overhead guard
- If the sensor is mounted below the guard, or is very close to the operator's head, SEEN recommends reducing the volume in the sensor settings.
- Do not drill into any ROPS or FOPS structural elements
- A DC/DC voltage reducer may be required on battery electric machines

Sensor settings*

CRITICAL ALERT	3m
EARLY WARNING	+1m
REVERSE DEPENDENT ALERT	
Sensor can only alert when the reverse signal is on	
VOLUME	Reduced
BOOT NOTIFICATION	Short

*An IRIS 860 Setup Dongle (SI-138) is required if you need to change the sensor settings.

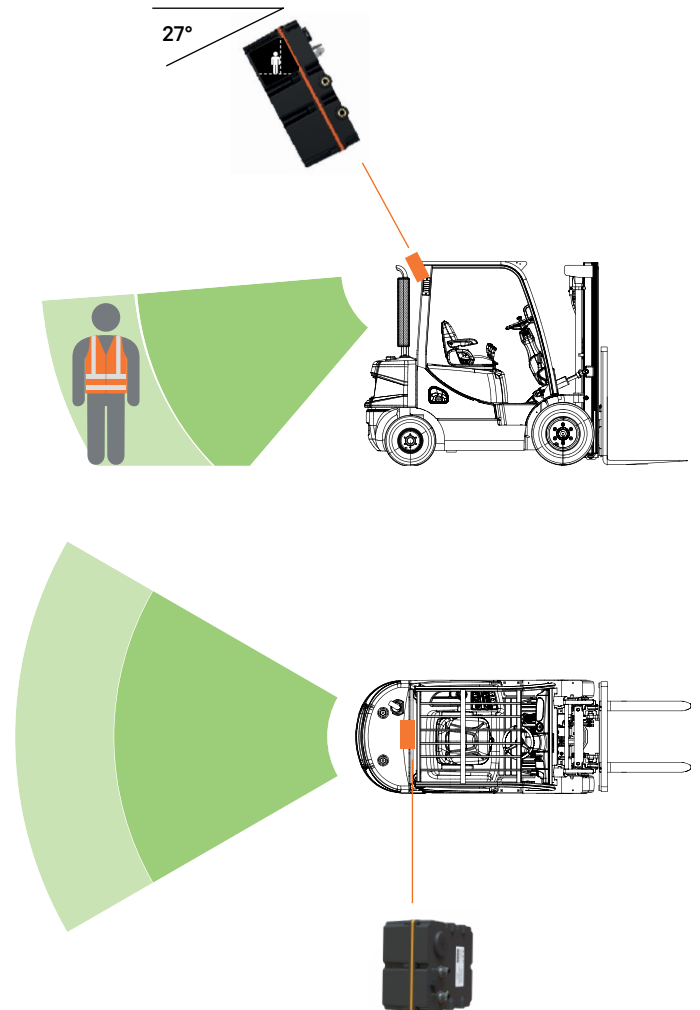

SEEN equipment to install

1 x IRIS 860 sensor SI-120

Installer notes

- The sensor can be located either below or above the overhead guard unless the truck has a container mast, in which case the sensor must be mounted below the overhead guard
- If the sensor is mounted below the guard, or is very close to the operator's head, SEEN recommends reducing the volume in the sensor settings.
- Do not drill into any ROPS or FOPS structural elements
- A DC/DC voltage reducer may be required on battery electric machines

Sensor settings*

CRITICAL ALERT	3m
EARLY WARNING	+1m
REVERSE DEPENDENT ALERT	Sensor can only alert when the reverse signal is on
VOLUME	Reduced
BOOT NOTIFICATION	Short

*An IRIS 860 Setup Dongle (SI-138) is required if you need to change the sensor settings.

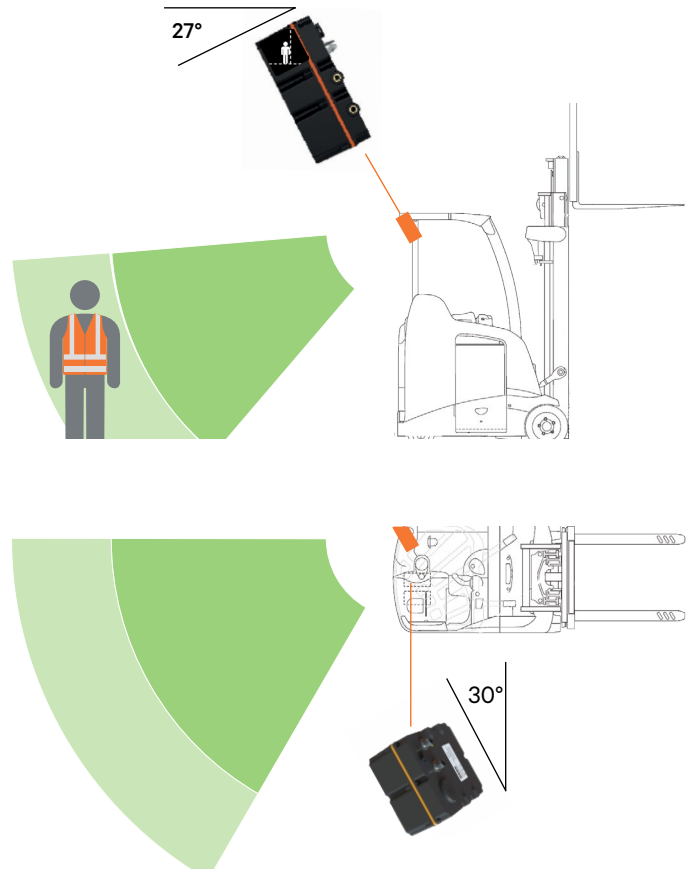

This setup applies to all Reach Trucks (full height mast, container mast, stand-up and sit-down).

SEEN equipment to install

1 x IRIS 860 sensor SI-120

Installer notes

- The sensor can be located either below or above the overhead guard unless the truck has a container mast, in which case the sensor must be mounted below the overhead guard
- If the sensor is mounted below the guard, or is very close to the operator's head, SEEN recommends reducing the volume in the sensor settings.
- Do not drill into any ROPS or FOPS structural elements
- A DC/DC voltage reducer may be required

Sensor settings*

CRITICAL ALERT	3m
EARLY WARNING	+1m
REVERSE DEPENDENT ALERT	
Sensor can only alert when the reverse signal is on	
VOLUME	Reduced
BOOT NOTIFICATION	Short

*An IRIS 860 Setup Dongle (SI-138) is required if you need to change the sensor settings.

Due to the slightly higher mounting position, the sensor should be angled down approximately 5° more than on a standard counter-balance forklift (which is 27°).

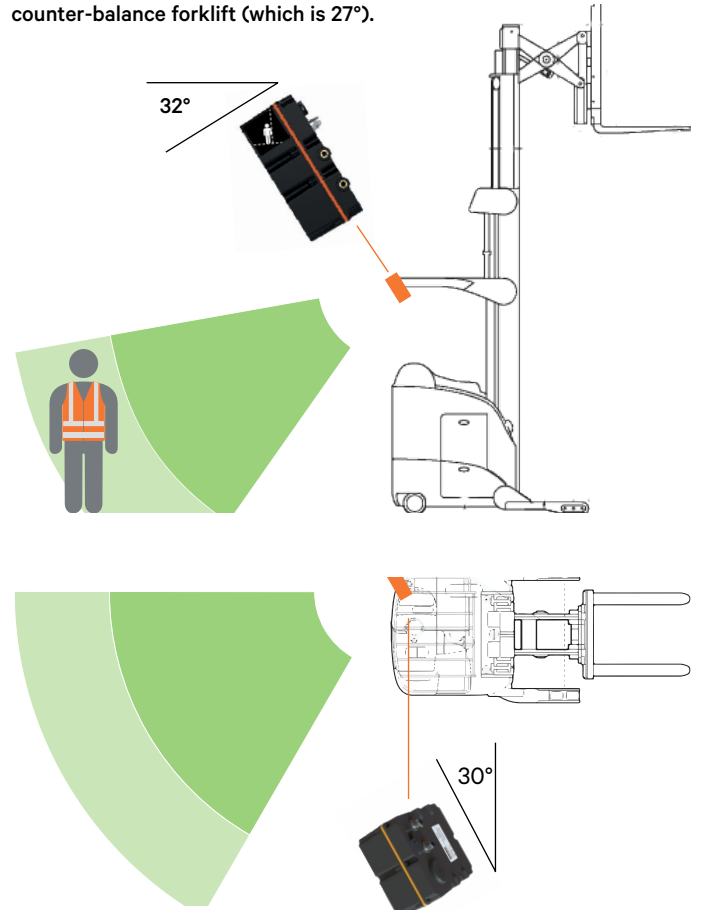



IRIS 860 SENSOR SETTINGS

CONTENTS

Sensor Settings	30
How to change the sensor settings	31

Sensor settings

The sensor has software to control the following settings:

- Critical alert detection zone
- Early-warning detection zone
- Direction-dependent alert
- Alert volume
- Boot Notification

Factory default settings

- 3m critical alert zone
- + 1m early-warning zone
- Sensor can only alert when receiving a reverse signal from the vehicle
- Alert Volume: Normal
- Boot Notification: Long

Changing the settings

The sensor settings can be changed to suit the specific operating environment.

The customer (on site Manager) is responsible for deciding what settings are appropriate for their workplace. They can change the sensor settings themselves, or may provide the installer with a template containing the required settings changes.

Related section

[Machine Templates](#) - Pg 26

How to change the settings

To change the sensor settings you will need to use an IRIS 860 Setup Dongle (P/n SI-138).

Using the IRIS 860 Setup Dongle

The IRIS 860 Setup Dongle allows the sensor settings to be changed using a Bluetooth enabled mobile device.

Related section

[IRIS 860 Setup Dongle](#) - Pg 24

Requirements

- IRIS 860 Setup Dongle (P/n SI-138)
- USB-C power source (not included with the dongle)
- Android or iOS device
- SEEN Sensor Setup App (Download at Google Play or the App Store).

Instructions

1. Power the dongle from a USB-C power-source (not supplied with the dongle)
2. Launch the SEEN Sensor Setup App and follow the onscreen instructions

Related section

[Changing settings via Cab Box](#) - Pg 38

Related resource

Changing settings via USB Config Cable -
www.seensafety.com/change-sensor-settings-usb-config



TECHNICAL REFERENCE RESOURCES

CONTENTS

Using a DC/DC voltage converter	33
Connect to a third party accessory	35
Sensor Internal Self Check function	37
Changing settings via Cab Box Sensor Cable	38
Cab Box Sensor Cable shortening and threading	39
IRIS-i camera Internal Memory	40

Using a DC/DC voltage converter

If voltage reduction is required

Use a DC/DC converter that:

- is suitable for use on automotive equipment;
- is rated to the machine's power supply voltage;
- can output 12 or 24 volts at 2 amps. (Use a 5 amp converter if using a Cab Box with multiple sensors plus accessories).

Option 1: Non-isolated DC/DC converter

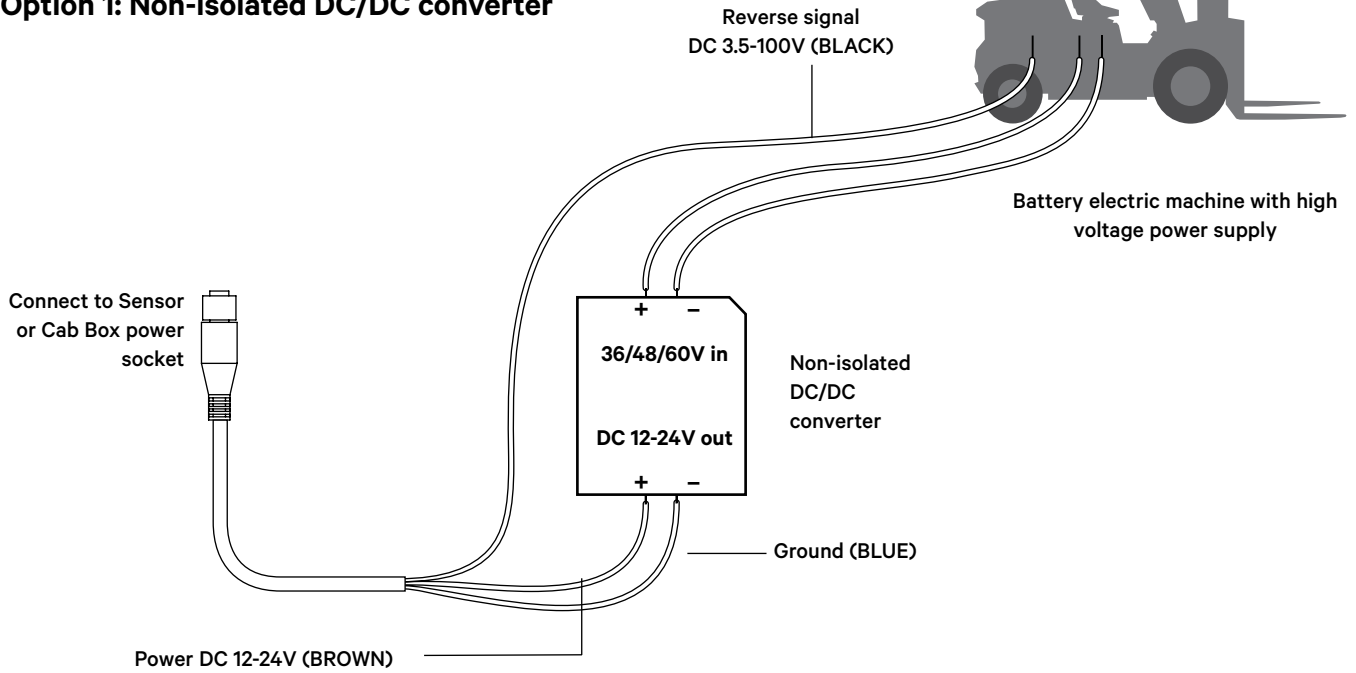

Option 2: Use an isolated DC/DC converter with a bridge

Isolated converters can be bridged as shown in the diagram opposite. Bridging is required because the reverse signal input is electrically isolated from the IRIS 860 sensor ground (-V in) meaning the reverse signal is not grounded.

If the reverse signal does not share the same ground reference as the sensor (or Cab Box), the sensor will not receive the reverse signal and will not alert as expected.

A bridge across the DC/DC converter isolation barrier (as shown by the dashed line) is required so that both circuits share a common ground.

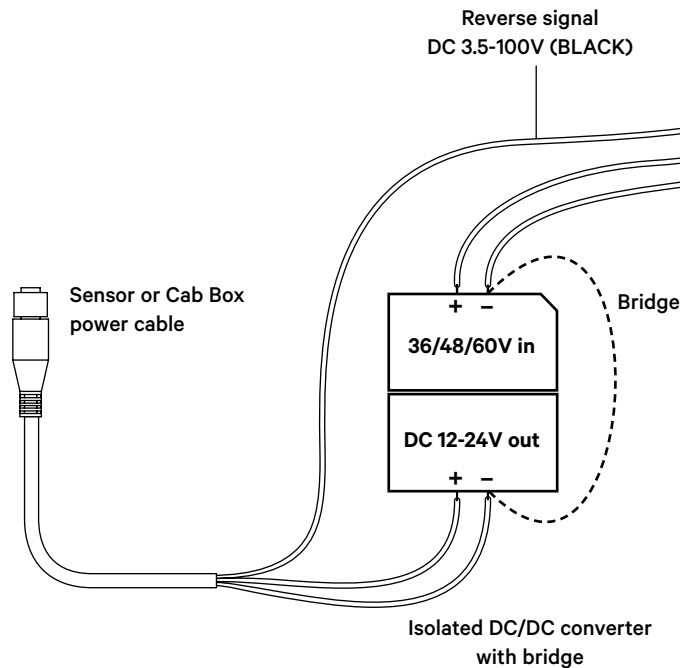

WARNING. If another accessory shares the DC/DC converter and requires an isolation barrier for safety, use a separate DC/DC converter or use a relay (see [page 34](#)).

Option 3: Use an isolated DC/DC converter with a relay

When using an isolated DC/DC converter without a bridge, the reverse signal will not share the same ground reference as the sensor (or Cab Box), and the sensor will not receive the reverse signal. This may lead to unexpected behaviour.

To overcome this a relay must be added as shown in the diagram below. The relay should be:

- Suitable for automotive use
- Rated to the voltage of the reverse signal input
- Include a flywheel diode for protection.

When active, the relay allows the isolated supply voltage to appear on the reverse signal input to the sensor.

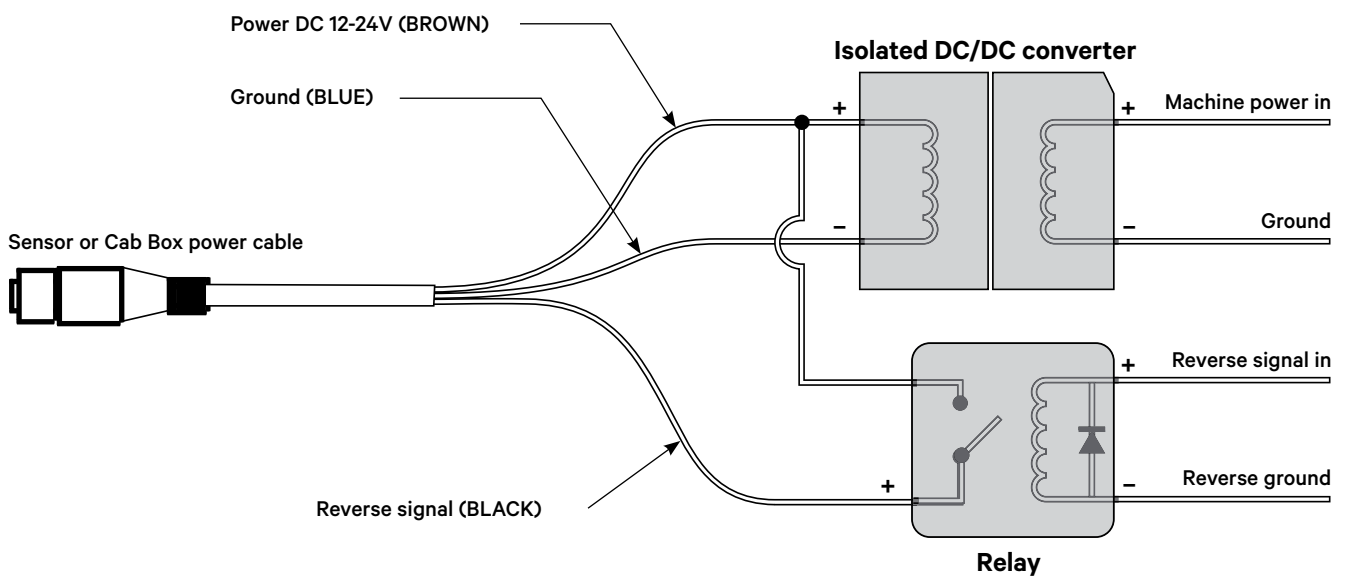

The 8-pin M12 accessory socket outputs an electrical signal while the IRIS 860 is detecting. The signal output behaviour can be controlled in the IRIS 860 Sensor Settings App. By default the detection signal output is only high during a detection in the Critical Alert zone.

Accessory Cable

The IRIS 860 Accessory Cable (P/n SI-121) is needed to connect a third-party accessory such as a light.

IMPORTANT. The Accessory Cable is for the IRIS 860 sensor only. It cannot be used on a Cab Box.

Pin no.	Wire colour	Description
1	Brown	12V accessory power supply
2	White	Ground / Earth
3	Blue	Detection NPN
4	Black	Detection 3.6V logic output
5	Grey	Do not connect
6	Pink	Detection 12V logic output

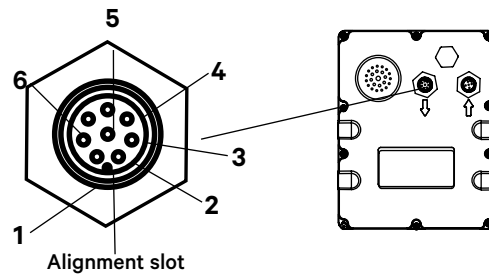

Note. Refer to the accessory socket pin-out diagram on page 43 for the complete specification.

Accessory use-case examples

The sensor is only capable of providing 200mA of current on its accessory port power output. Please contact us if you want to add an accessory that requires more power.

External buzzer or light

On detection the NPN transistor switch closes putting 12V across the connected accessory. The maximum supply current is 500mA.

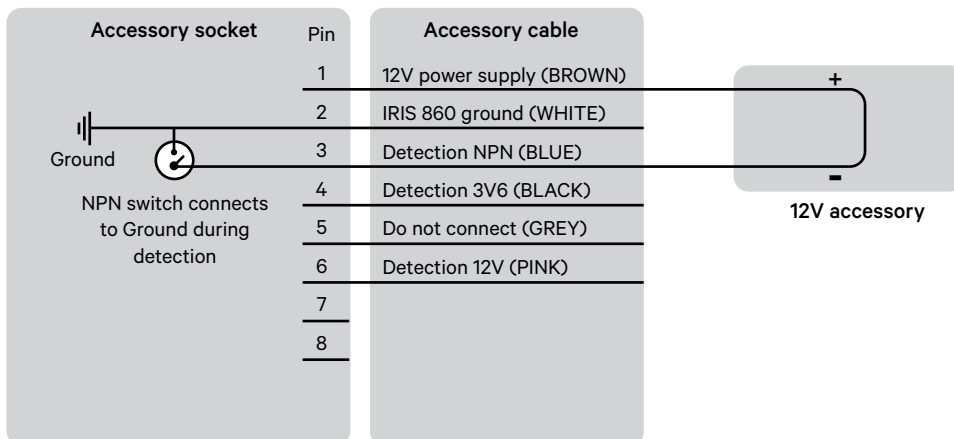

External relay

On detection the NPN transistor switch closes putting 12V across the relay. A flywheel diode is required across the relay coil to protect the NPN transistor against the coil transient when the detection event ends and the coil is switched off.

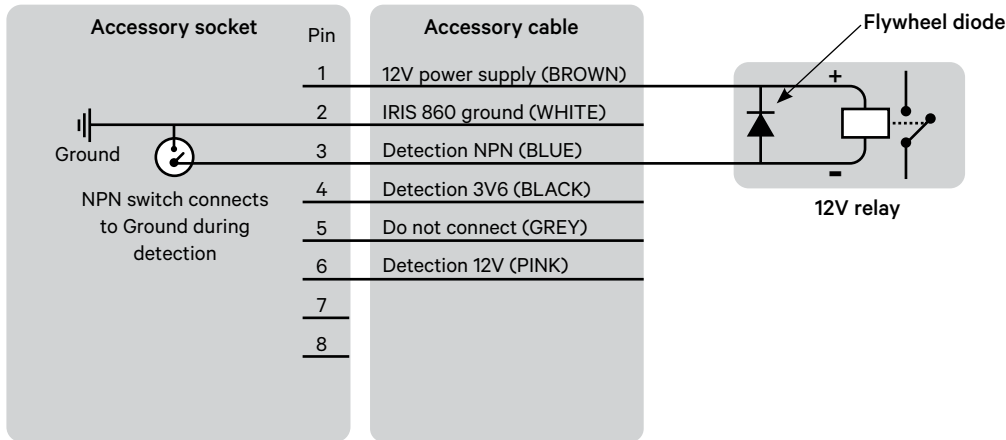

Accessory with digital input

The IRIS 860 accessory power supply is used to power the third party accessory (maximum supply current 500mA). This is a low power output and can only supply a few milliamps of current. If required, add an external regulator to limit the 12V detection logic output voltage (e.g. down to 5V or 3.3V) or use Detection 3V6 (black) for a 3.6V detection output.

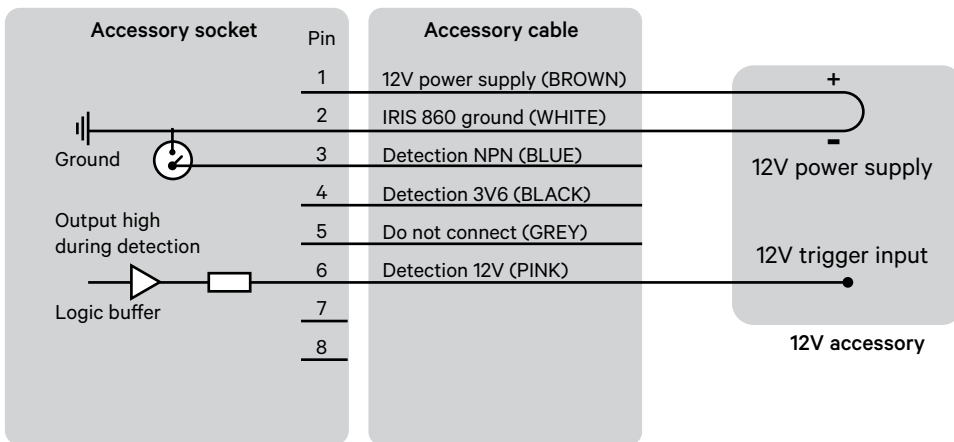

IRIS 860 sensors have an automatic internal self-checking function. If a fault is detected the sensor (and Cab Box if used) will flash and beep a pattern indicating the type of fault detected.

Window contamination dust/dirt

Situation: The sensor operates in a dusty or dirty environment

Problem: The sensor windows are excessively contaminated.

Indication: Continuous beep and flash sequence long-short-short, long-short-short etc. --- --- --- ---

Solution: Clean the sensor windows

Window contamination ice/condensation

Situation: The sensor operates in a cold store / freezer environment.

Problem: Ice or condensation on the windows is triggering the window self check test.

Indication: Beep and flash sequence long-short-short, long-short-short etc. --- --- --- ---

Possible solution: First check whether pedestrian workers can be reliably detected with ice or condensation present on the windows. If detection is reliable, then the window self check function may be turned off using the setup app. **Use this setting with caution** because the window self-check function will be disabled. Contact SEEN customer support for more information.

Sensor internal fault

Any error sequence that is NOT long-short-short, long-short-short indicates an internal fault. Unplug the sensor and contact your reseller or supplier to arrange replacement.

IRIS 860 sensors have no user-serviceable parts.

Changing settings via Cab Box Sensor Cable

IRIS 860 sensor

If a Cab Box is used, the sensor settings can be changed from within the cab of the machine.

Requirements

- IRIS 860 sensor connected to an IRIS 860 Cab Box via a Cab Box Sensor Cable
- IRIS 860 Setup Dongle (P/N SI-138)
- IRIS 860 Cable Adapter (P/N SI-124)

Instructions

1. Unplug the Cab Box Sensor Cable from the Cab Box
2. Attach the Cab Box Sensor Cable to the Cable Adapter
3. Attach the Cable Adapter to the IRIS 860 Setup Dongle, then follow the Dongle instructions in the section above
4. Once the settings have been changed accordingly, you can unplug the Cab Box Sensor Cable from the Cable Adapter and replug it back into the Cab Box.

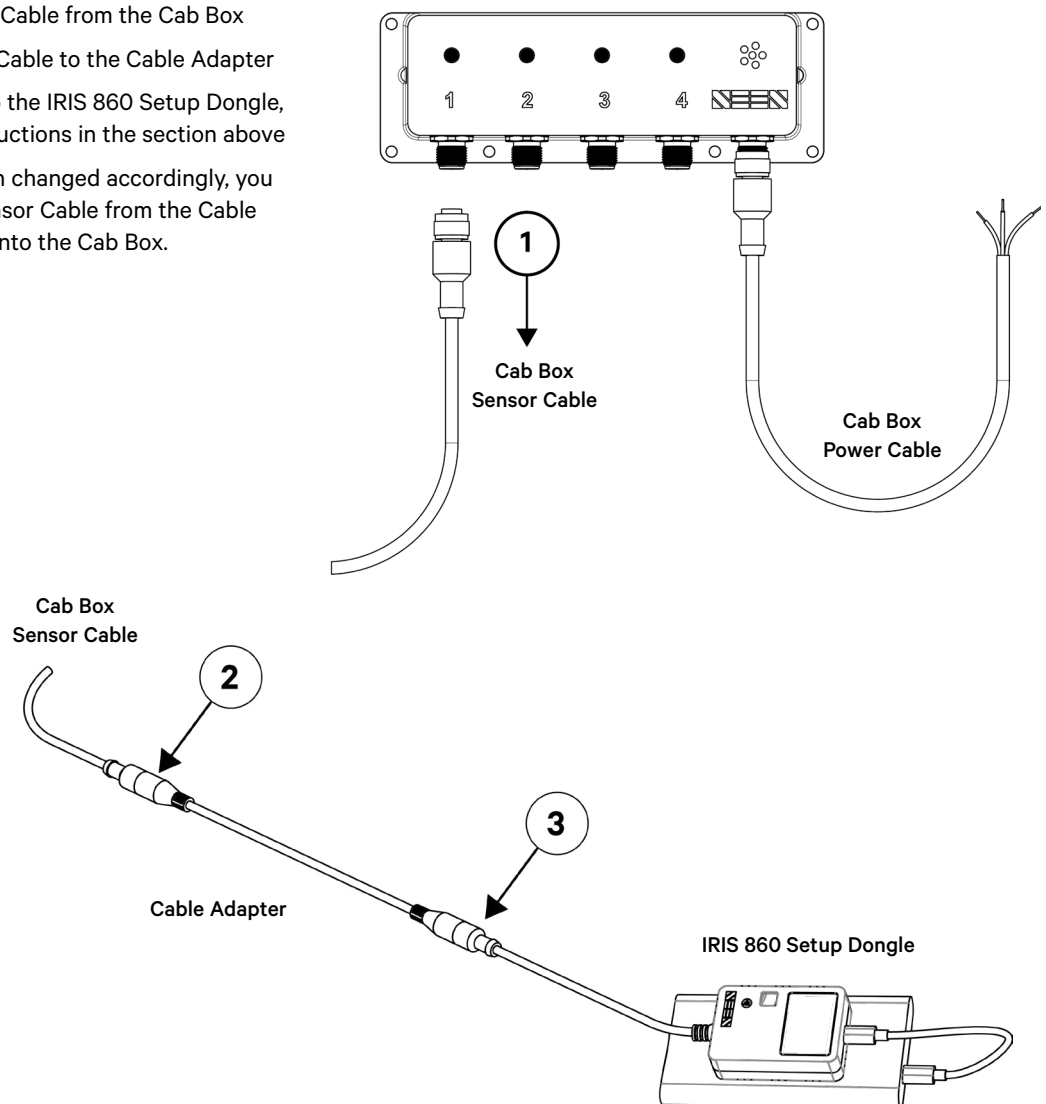

Related section

[How to change the sensor settings \(without Cab Box\)](#)

- Pg 31

The end of the Cab Box Sensor Cable has a re-wireable plug which can be removed to shorten the cable or to facilitate threading the cable through a small hole in the vehicle chassis

When re-wiring the plug, check that the wire colours match the diagram below. Use the screw-block as a reference.

IMPORTANT. The re-wireable plug should be connected to the Cab Box to protect it from the elements. The moulded end should be connected to the sensor.

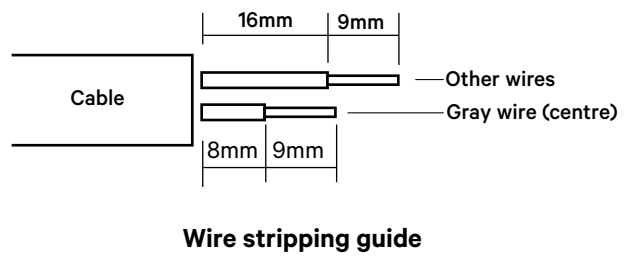
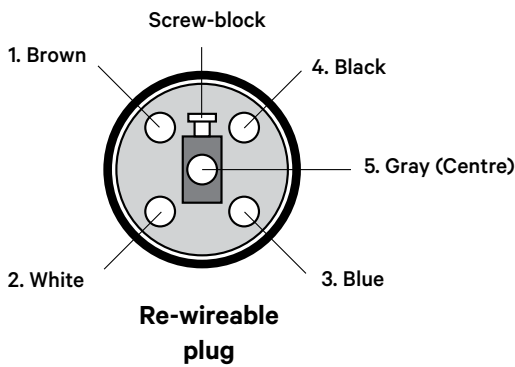
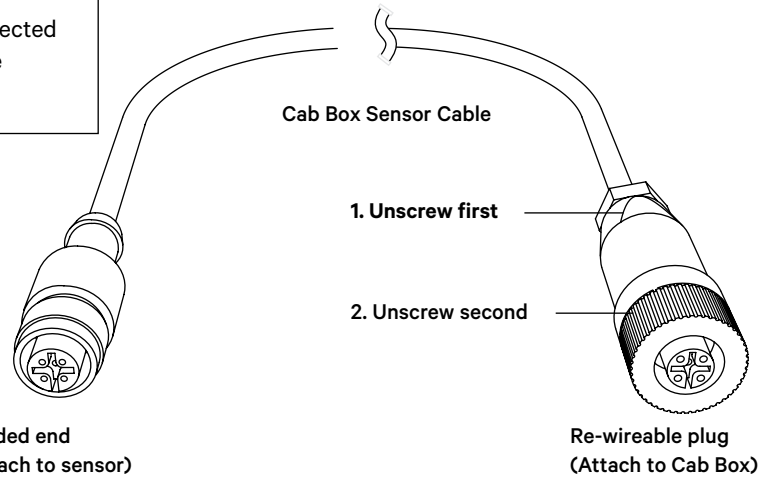

Related section
[Cab Box Wiring](#) - Pg. 14

The IRIS-i camera's internal memory stores detection data until it is uploaded to SEEN Insight, or it is over-written by new data.

Detection event data

Information about each detection (data and still-image) is immediately uploaded to SEEN Insight when the camera is online. If the network connection is lost, the camera can store up to 1,000 detection event records which will be uploaded next time the camera connects.

Detection event video clips

The camera can store approximately 12,000 detection event videos before they start to be over-written. Detection event videos that are still in the camera's memory can be uploaded to SEEN Insight. Once the camera's memory buffer is full, the oldest videos will start to be over-written by new detection event videos. Sound is not recorded.

Rolling video buffer

A 6 hour rolling video buffer is saved to the camera's memory. This video buffer is continuously over-written by new material when the camera is powered on. Sound is not recorded.

Emergency procedure

In the event of an emergency the camera should be removed from the machine and not powered on to ensure data is not over-written or lost. Contact support@seensafety.com

*The exact number will vary depending on the duration of each event.



PRODUCT SPECIFICATIONS

CONTENTS

IRIS 860 sensor	42
IRIS 860 Cab Box	44
IRIS-i camera	46

Input power	DC 12–80V \approx 0.7A or DC 12–24V \approx 0.7A Check sensor voltage sticker	Safety	Caution Class I LASER PRODUCT. Disassembly or modification of this device may result in hazardous radiation exposure
Direction signal input	DC 3.5–100V \approx 1mA	Standards	IEC 61000-6-4 (EMC emissions) IEC 61000-4-2 (EMC immunity) IEC 60825-1:2014 (Laser eye safety) IEC 61010-2-201:2017 (Electrical equipment safety)
Power consumption	2.0W max (sensor only) 8.0W max (with attached accessories)	Lighting	Immune from sunlight interference or ambient lighting conditions.
Detection range	0.8m - 8.0m / 2.6ft - 26ft	Ingress protection	IP67
Detection area	60 degrees horizontal x 45 degrees vertical	Enclosure	ASA injection moulded plastic
Detection target	Class II day/night high visibility safety apparel / PPE and other retro-reflective material	Mounting	4 x M6 brass inserts
Latency	Minimum detection time: 0.05s Maximum detection time: 0.33s Median detection time: 0.19s	Windows	Hard coated IR filtered PMMA
Maintenance	No scheduled maintenance required	Weight	0.48 kg
Buzzer	94dB at 1m 3500Hz	Dimensions	125mm x 160mm x 85mm
Connectors	M12 5-pin and M12 8-pin	Operating temperature:	-20° to +60° C / -4° to +140° F ambient (non condensing)
Laser type	Pulsed infrared 905nm non-visible		

Product specifications are subject to change without notice to improve reliability, function, design or otherwise.



Example IRIS 860 sensor label with serial number A-01000

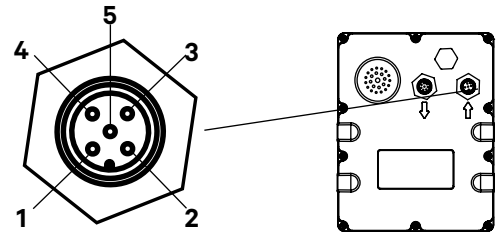

IRIS 860 sensor power socket (M12 5-pin)

Pin	Name	Description	Direction	Max. input voltage	Min. input voltage	Input high voltage	Input low voltage	Output high voltage	Output low voltage	Conditions	Notes
1	Vin +	Power supply positive	Input	24v or 80v. Check sensor	10.8v	-	-	-	-	-	8W maximum power draw (with attached accessory). 2W maximum for sensor only
2	Vin -	Power supply negative (ground)	-	-	-	-	-	-	-	-	System / chassis ground
3	System status	High when sensor is operating	Output	-	-	-	-	5.2v max. 4.5v min.	0.1v max.	1K Ohm load to ground	PNP output
4	Detection	High when sensor detects	Output	-	-	-	-	5.2v max. 4.5v min.	0.1v max.	1K Ohm load to ground	PNP output
5	Direction	Reverse/ direction signal input	Input	100v	0v	3.5v min.	1v max.	-	-	-	Input current is less than 1.0 mA

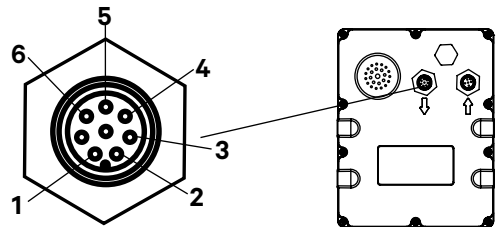

IRIS 860 sensor accessory socket (M12 8-pin)

Pin	Name	Description	Direction	Max. input voltage	Min. input voltage	Input high voltage	Input low voltage	Output high voltage	Output low voltage	Conditions	Notes
1	12V out	Accessory power supply	Output	-	-	-	-	12.1v max. 10v min.	-	Supply voltage 12v and drawing 200mA from accessory supply pin	Used to power an external device
2	Vin -	Accessory supply negative (ground)	-	-	-	-	-	-	-	-	System / chassis ground
3	Detection NPN	Output during detection	Output	-	-	-	-	30v max.	0.8v max.	0.8v output low max when sinking 500 mA	NPN output, max blocking voltage 30v
4	Detection 3V6	Output during detection (low voltage logic)	Output	-	-	-	-	3.6v max. 2.0v min.	-	Source / sink 100 uA max.	-
5	Do not connect										
6	Detection 12V	Output during detection (high voltage logic)	Output	-	-	-	-	11v max. 9.3v min.	-	Supply voltage 12v, 2K Ohm load to ground	470 Ohm internal resistor in series with this output

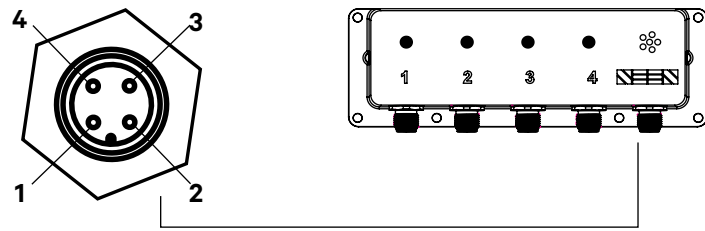

1. Cab Box power socket (M12 4-pin)

Pin	Name	Description	Direction	Max. input voltage	Min. input voltage	Input high voltage	Input low voltage	Output high voltage	Output low voltage	Conditions	Notes
1	Vin +	Power supply positive	Input	30v	10.8v	-	-	-	-	-	48W (12V @ 4Amps) maximum power draw
2	Vin -	Power supply negative (ground)	-	-	-	-	-	-	-	-	System / chassis ground
3	Direction	Reverse/direction signal input	Input	100v	0v	3.5V min.	1V max	-	-	-	Input current is less than 1.0mA

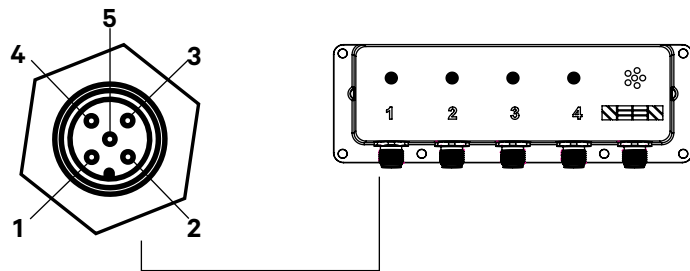

2. Cab Box sensor cable socket (M12 5-pin x4)

Pin	Name	Description	Direction	Max. input voltage	Min. input voltage	Input high voltage	Input low voltage	Output high voltage	Output low voltage	Conditions	Notes
1	Vout +	Power supply output to IRIS 860 sensor or IRIS-i camera	Output	-	-	-	-	30V	0V	-	The output supply voltage matches the input supply voltage
2	Vout -	Power supply negative (ground)	-	-	-	-	-	-	-	-	System / chassis ground
3	System status	High when system is operating	Input	6V	0V	4V	1V	-	-	-	Green LED
4	Detection	High during detection	Input	6V	0V	4V	1V	-	-	-	Red LED
5	Reverse signal output	Reverse/direction signal output to IRIS 860 sensor or IRIS-i camera	Output	-	-	-	-	30V	0V	-	PNP output. The reverse output matches the supply voltage when the reverse/direction signal from the machine is high

3. IRIS 860 Cab Box specifications

Input power (ignition)	DC 12-24V --- 4A	Ingress protection	None
Direction signal input	DC 3.5-100V --- 1mA	Enclosure	ASA injection moulded plastic
Power consumption	48W max (with 4 attached sensors and accessories)	Standards	IEC 61000-6-4 (EMC emissions) IEC 61000-4-2 (EMC immunity) IEC 61010-2-201:2017 (Electrical equipment safety)
Maintenance	No scheduled maintenance required. Keep buzzer clear	Weight	0.25kg
Buzzer	85 dB at 1m 2500Hz	Dimensions	178mm x 66mm x 38mm
Operating temperature:	-20° to +60° C / -4° to +140° F ambient		

Product specifications are subject to change without notice to improve reliability, function, design or otherwise.

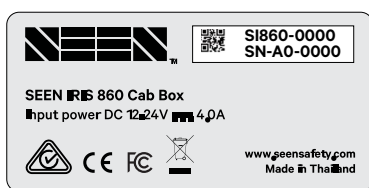

Cab Box label

Input power	DC12-80V. Electrical --- 2.0A	Standards	FCC Part 15 PTCRB EN 301489 EMC emissions and immunity
Direction signal input	DC 3.5-100V electrical --- 1mA	Ingress protection	IP67. Protected from dust ingress and water ingress at 1 metre submersion for 30 minutes. Avoid high pressure water jets
Power consumption	24W max with sensor attached	Enclosure	ASA injection molded plastic
Camera field of view	70 degrees horizontal x 55 degrees vertical	Window	Hard coated PMMA with oleophobic and anti-reflective coatings.
Maintenance	Clean with water and a soft clean cloth. Avoid all solvents, degreasers, petroleum or alcohol cleaning products	Operating temperature	-20 to +50 degrees C ambient (non condensing)
Connectors	M12 5-pin (power supply) M12 8-pin (to sensor) Dual SMA antenna connectors (RF connector in centre)	Dimensions	110mm H x 64mm W x 66mm D
Weight	0.26kg		

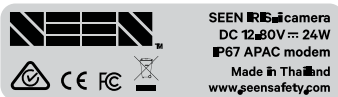

IRIS-i camera label

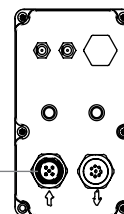

5 pin power socket

Power socket (M12 5-pin)

Pin	Name	Description	Direction	Max. input voltage	Min. input voltage	Input high voltage	Input low voltage	Output high voltage	Output low voltage	Conditions	Notes
1	Vin +	Supply positive	Input	92v	10.8v	-	-	-	-	-	24W maximum power draw
2	Vin -	Supply negative (ground)	-	-	-	-	-	-	-	-	System / chassis ground
3	System status	High when system operating	Output	-	-	-	-	5.5v max. 4.5v min.	-	2.7K Ohm load to ground	PNP output
4	Detection	High when target detected	Output	-	-	-	-	5.5V max 4.5V min.	-	2.7K Ohm load to ground	PNP output
5	Direction signal in	Input	Input	100v	0v	3.5v min.	1v max.	-	-	-	Input current is less than 1.0 mA

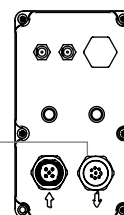

8 pin sensor socket

Sensor socket (M12 8-pin)

Pin	Name	Description	Direction	Max. input voltage	Min. input voltage	Input high voltage	Input low voltage	Output high voltage	Output low voltage	Conditions	Notes
1	Vout +	Supply output to IRIS 860 sensor	Output	-	-	-	-	17.5v	-	-	Limits IRIS 860 supply voltage to 16V
2	Vout -	Supply negative (ground)	-	-	-	-	-	-	-	-	System / chassis ground
3	Reserved										
4	Reserved										
5	Direction	Direction signal output to sensor	Output	-	-	-	-	17.5V max 6.8V min.	-	10K ohm load to ground	PNP output
6	Trigger in	Camera trigger input	Input	30V	0V	3.5V min.	0.7V max				High impedance external trigger input for the camera

Product specifications are subject to change without notice to improve reliability, function, design or otherwise.

IMPORTANT: If the equipment is used in a manner not specified by the manufacturer (SEEN Safety), the protection (Electrical safety) provided by the equipment may be impaired.



GENERAL

CONTENTS

Warranties	48
Maintenance	49
Support	49

Warranties

IRIS 860 sensor

IRIS 860 sensors have been designed for reliable long-term use on industrial vehicles in indoor or outdoor applications. The sensor is covered by a 2 year repair or replacement warranty on materials and workmanship. The warranty excludes general wear and tear, physical damage caused by direct impact to the sensor, over-tightening or misalignment of the M12 connectors, damage to the sensor windows, damage caused by high-pressure water jets, damage caused by chemical cleaners (including alcohol, benzene, thinners, and degreasers), or damage caused by over-voltage to the power supply. IRIS 860 sensors have no user serviceable parts.

Opening the enclosure will void the warranty.

IRIS 860 Cab Box

The IRIS 860 Cab Box is covered by a 1 year repair or replacement warranty on materials and workmanship. The warranty excludes general wear and tear, physical damage caused by direct impact, damage caused by exposure to moisture, over-tightening or misalignment of the M12 connectors, or damage caused by over-voltage to the power supply.

IRIS-i camera

IRIS-i cameras have been designed for reliable long-term use on industrial vehicles in indoor or outdoor applications. The camera is covered by a 1 year replacement warranty on materials and workmanship. The warranty excludes general wear and tear, physical damage caused by direct impact to the camera, over-tightening or misalignment of the M12 connectors, damage to the camera window, damage caused by high-pressure water jets, damage caused by chemical cleaners (including alcohol, benzene, thinners, and degreasers), or damage caused by over-voltage to the power supply. IRIS-i cameras have no user serviceable parts. Opening the enclosure will void the warranty.

Maintenance

IRIS 860 sensors and IRIS-i cameras have no user-serviceable parts.

Other than keeping the windows and buzzer free of dust and dirt, no scheduled maintenance is required.

Remove dust and dirt using clean water and a clean non-abrasive cloth.

The sensor and the camera are rated IP67.

Do not use high pressure water jets to clean.

Do not use chemical cleaners including alcohol, benzene, thinners, and degreasers.

Opening the enclosure will void the warranty.

Support

If you require support, please contact support@seensafety.com or phone +1 888 858 4648